

ANKER ADA-Pad

ACCESSIBLE SERVICE AT SELF-SERVICE TERMINALS

Accessible operation

The ADA-Pad from ANKER makes every self-service terminal terminal barrier-free – whether self-checkouts in the super-market, self-service scales, ticket machines or information terminals. With haptic buttons, audio support and flexible installation options, it enables easy navigation for people with visual impairments or limited motor skills. The ADA-Pad makes it possible self-service terminals to comply with the current legal comply with current legal accessibility requirements.

Advantages

- **Legal requirements** - ADA Act requires barrier-free design of digital systems
- **Inclusion & participation** - Equal use for people with visual impairments, reading difficulties or limited fine motor skills
- **Facilitated navigation** - Haptic button control & audio support for barrier-free menu handling
- **Helps with ADA compliance** - For touchscreen operated self-service terminals
- **Audio support** - Outputs digital content via headphones for auditory user guidance
- **Flexible integration** - Horizontal, vertical, pole mounting & customized brackets
- **Easy to find** - RGB backlighting facilitates identification
- **Hardware as enabler** - Supports software solutions for maximum accessibility
- **Future-proof** - Early implementation protects against future requirements

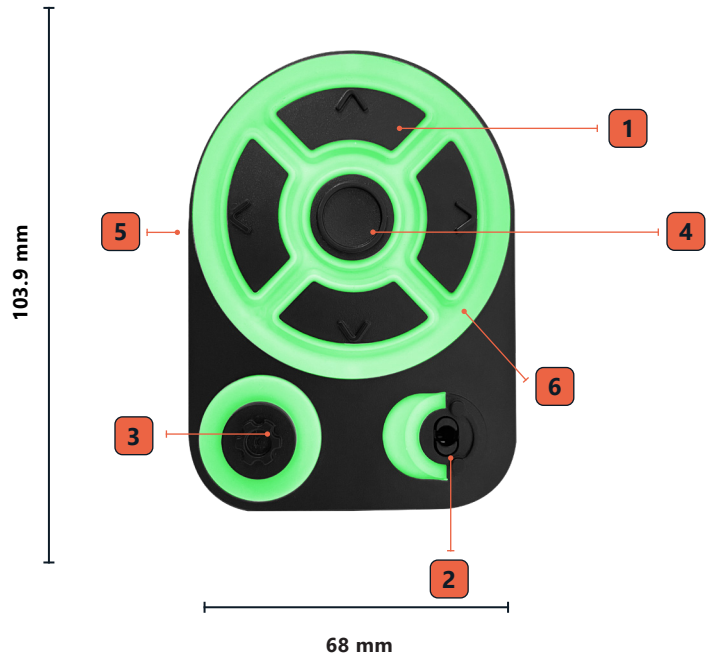

Equipment

1 Tactile arrow keys for navigate	4 Tactile ENTER button to confirm/select
2 Audiojack for headphones and microphone	5 Dip switch on the rear for flexible installation; vertical or horizontal
3 Tactile function button for opening menus	6 RGB backlighting controllable in 3 zones

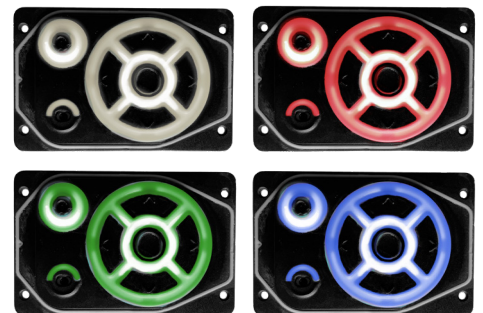

Exemplary color variants of the lighting

Subject to change without notice - The ADA-Pad is currently in the final stages of product development.

This data sheets provides information about accessibility laws and regulations, but is not legal advice. You should consult a lawyer for advice on specific legal issues or problems.

ANKER ADA-Pad

Installation solutions



ADA-Pad installation solution on the self-service terminal

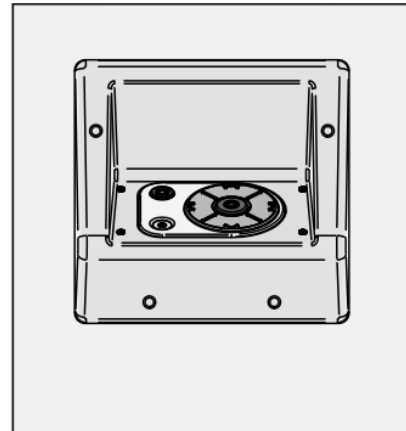

ADA-Pad installation solution on the self-service terminal



ADA-Pad installation solution for poles

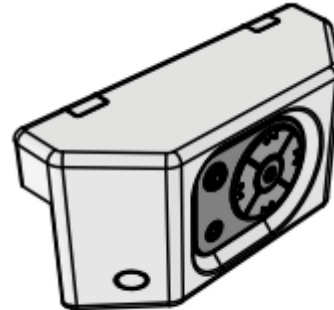

ADA-Pad attachment/front mounting solution for e.g. scales

Americans with Disabilities Act (ADA) | United States

The Americans with Disabilities Act (ADA) requires businesses and public services to make their facilities and technologies accessible to people with disabilities. For self-service kiosks, this means compliance with standards for reach, tactile and audio feedback, visual contrast, and alternative input options. The goal is to ensure equal access and usability for everyone, regardless of physical or sensory limitations.

